

3.3B Curbs

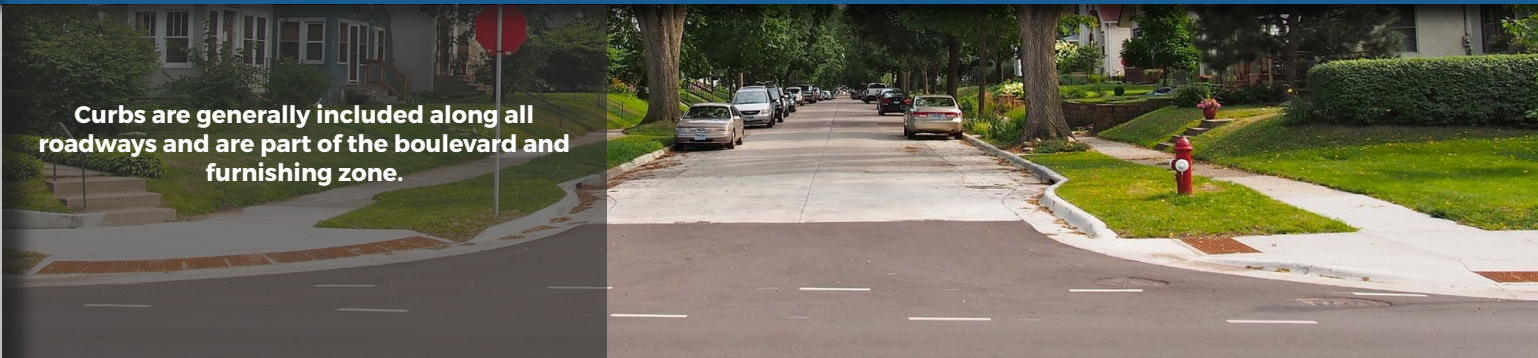

Curbs are generally included along all roadways and are part of the boulevard and furnishing zone.

INTRODUCTION

Curbs are generally included along all roadways and are part of the boulevard and furnishing zone. The curb is connected with the gutter, which is covered in the [roadways guidance](#).

6" curb tops (8" total width) are most common in Minneapolis. 12" curb tops (14" total width) are most common in downtown and are used on parkways (often with 1' gutter pans). See Figure 3.3B.1 and Figure 3.3B.2 for details for each curb.

Figure 3.3B.1:
B624 curb with 6" top

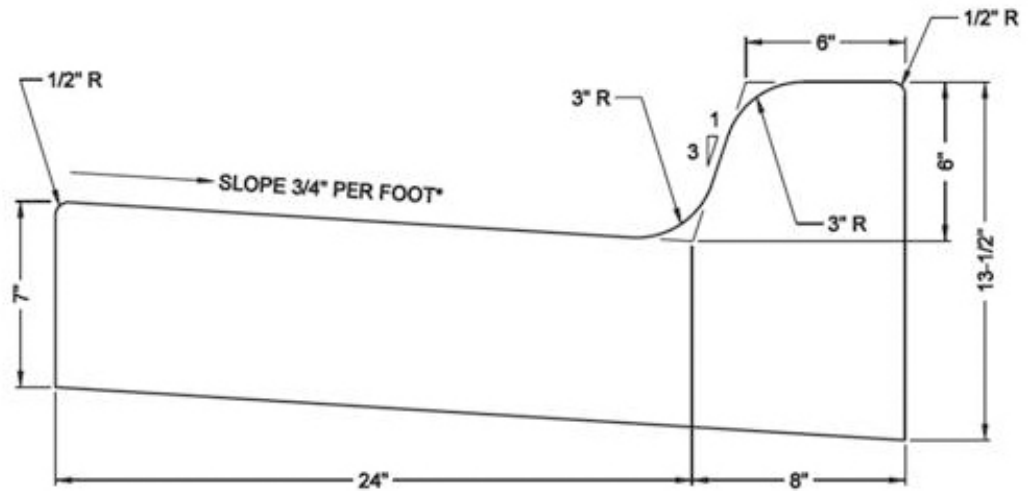

*SLOPE NOT TO EXCEED 1:20 AT CURB RAMPS

Figure 3.3B.2:
B624 Modified curb with 12" top

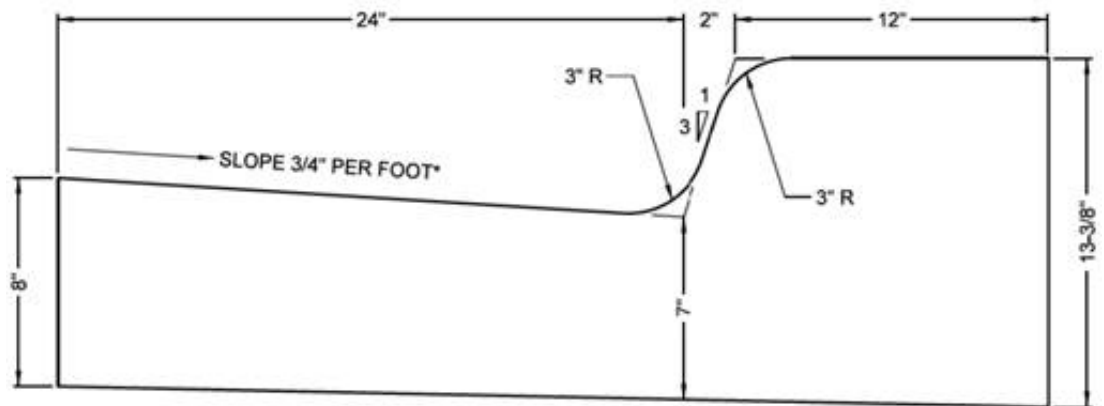

*SLOPE NOT TO EXCEED 1:20 AT CURB RAMPS